



# **MGC-10 Multi-Channel Dash Camera**

## DUAL DASH CAMERA

### INSTALL GUIDE

(847) 296-279

[sales@motorgc.com](mailto:sales@motorgc.com)

[www.motorgc.com](http://www.motorgc.com)

## **Important Notice**

1. Before installation, please park the vehicle on the horizontal ground and shut down the engine (do not park the vehicle on a ramp or an inclined road).
2. Please read the section of packing list carefully and check carefully at the time of unpacking.
3. Please read the section of tool list carefully and provide installation tools before product installation.
4. Before installation, please observe the vehicle environment and follow the principles below:
  - a. The installation position and cabling of the product shall neither affect the driver's view nor affect the adjustment of the rearview mirror and sun visor.
  - b. The lens for monitoring the road condition ahead of the vehicle must be within the working range of the windshield wiper.
  - c. The installation position of the camera for monitoring the driver in the vehicle shall comply with local regulations.
  - d. The installation location should be convenient for Micro SD card and SIM card replacement and maintenance.
5. The appropriate installation position shall be selected according to the vehicle environment, and this document is for reference only.
6. The appropriate power supply connection method shall be selected according to the vehicle environment. If loose wire connectors are adopted, connection to the power supply and all signal cables of vehicle is required, and shall be carried out by specialized personnel.

## Schematic Diagram of System Connection-Power Supply through OBD

- Dual-lens model

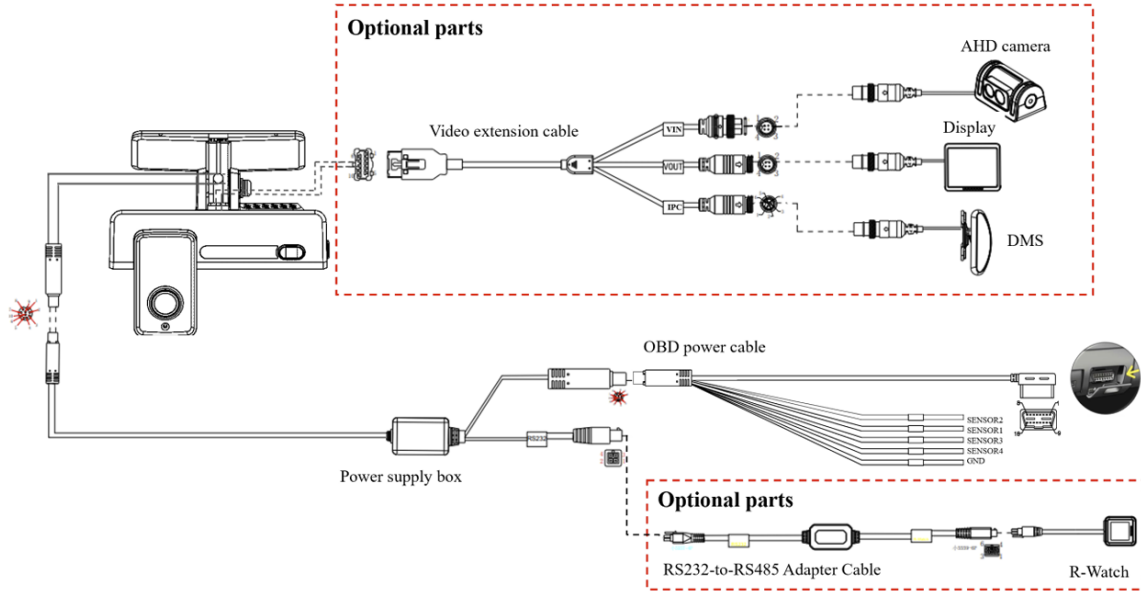

## Schematic Diagram of System Connection-Power Supply through Standard Power Cable

- Dual-lens model

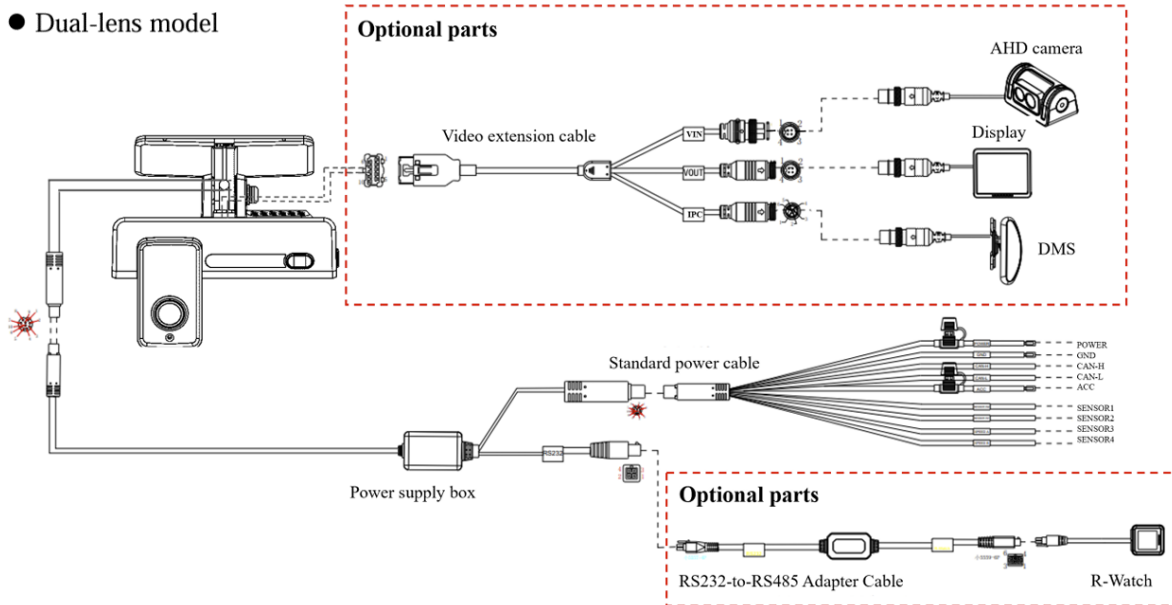

## Schematic Diagram of System Connection-Power Supply through Power Box Max

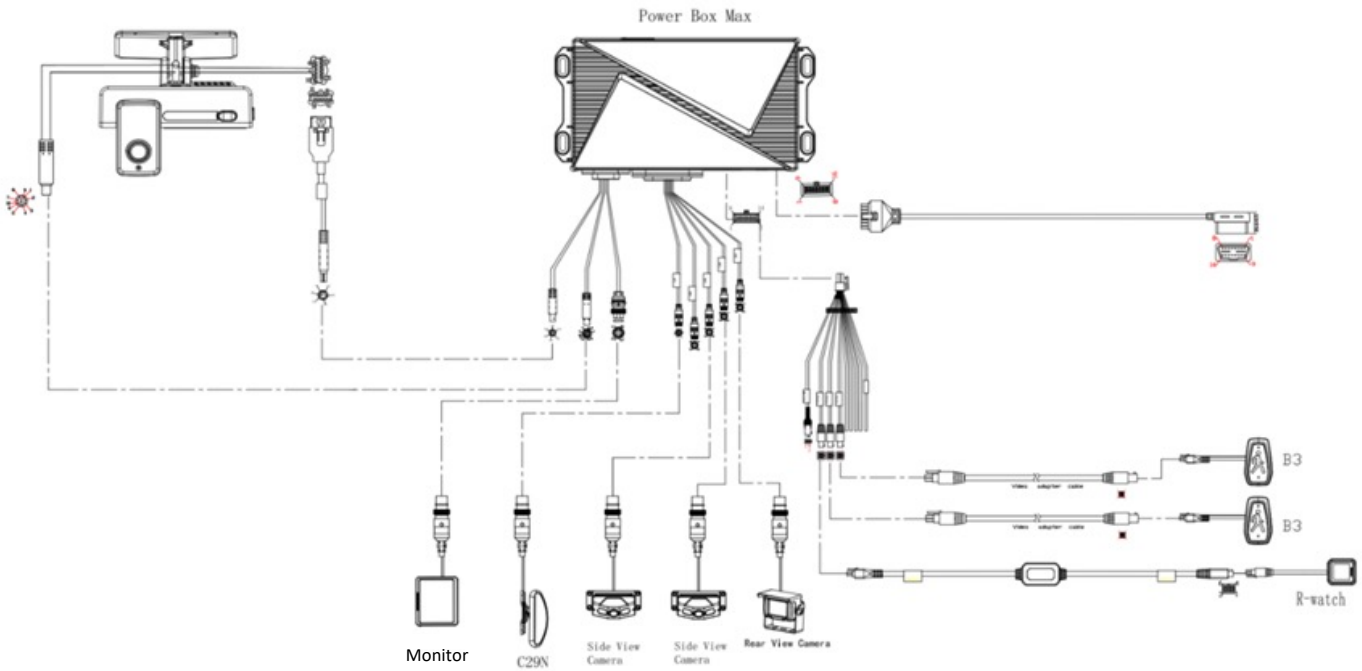

## Schematic Diagram of System Connection-Power Supply through Power Box Plus

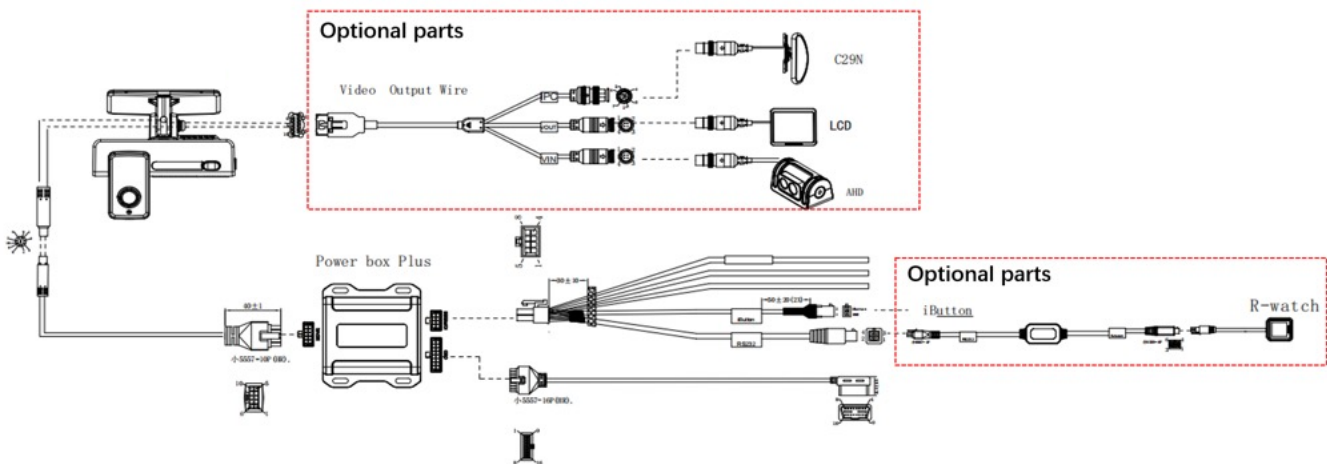

## **Preparation for Installation**

Relevant personnel must have a comprehensive understanding of the product's functions, applications, and overall components. They should possess knowledge of electrical circuits and vehicle structures, as well as common installation techniques for in-vehicle devices.

Prior to device installation, relevant personnel should be familiar with the specific vehicle model, the optimal installation locations for the dashcam and auxiliary cameras, the types and lengths of cables required for each vehicle model, and the list of supplementary materials needed. This ensures the successful completion of device installation and setup.

Confirmation of vehicle information is essential for a successful installation and to allocate responsibilities effectively, minimizing the risk of vehicle damage. Each installation step should only proceed after thorough confirmation, verified by both the vehicle owner or responsible party and the installation personnel.

Key steps to confirm before installation include:

- Inspecting the vehicle's exterior and interior for any existing damage.
- Testing the vehicle's ignition to ensure normal operation.
- Verifying the vehicle's power supply system is in optimal condition.

Note: Installation should commence only after confirming the above criteria are satisfactory and meet normal operational standards.

## Preparation for Installation Material and Tool List

1



MGC-10 Camera x1

2



Power supply box × 1

3



Optional  
Standard power cable × 1

4



Allen key × 1

5



Mounting bracket × 1

6



Bracket bolt × 1

7



Crowbar × 1

8









Desiccant × 1

9



Alcohol cotton × 1

## Status Indicator Lights of the Panel

LED Indicator Status	
Power status lights	 Off/Green Off: The device is not powered on Steady green: The device is powered normally
Alarm indicator light	 Off/Red Off: The device does not generate any alarm Red flashes three times: The device generates an alarm The fault indicator of the OBD port blinks twice every second until the fault is removed.
GPS signal indicator	 Off/Red Off: The device positioning runs normally Steady red: The device positioning runs abnormally (not positioned, or module not connected or damaged) Red flash (once per second): The device positioning is poor
Network status indicator	 Off/Red Off: The device is connected to the server normally Steady red: The device is connected to the server abnormally Red flash (once per second): The device is in flight mode Flight mode: When the vehicle enters the gas station, turn off the wireless signal of the device to ensure safety
Wi-Fi status indicator	 Off/Red/Green Off: The device is in Disable or Client mode Steady green: The device is in AP mode Steady red: The device Wi-Fi runs abnormally
Recording status indicator	 Off/Red Off: The built-in or extended camera runs normally Steady red: The built-in or extended camera stops (including privacy mode)/fails * When the video recording function is enabled ( <a href="#">main stream</a> and sub stream), the prompt will be given if no recording is detected. If the video recording

## Installation of SIM Card and Memory Card

Take out the Dashcam (power-off), and use the Allen key in the kit to open the card slot panel on the right of the Dashcam by turning counterclockwise.

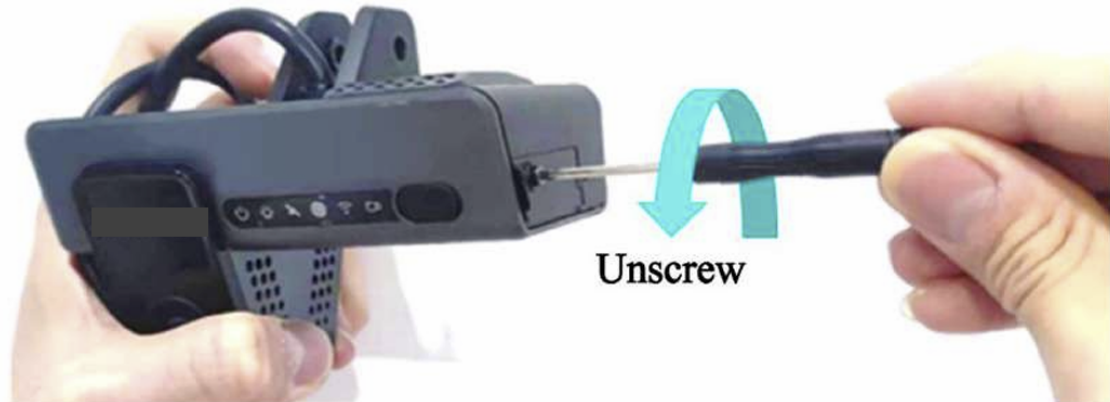

Install SIM card and Micro SD card as shown in the figure below (pay attention to the insertion direction of the cards).

If you feel smooth and flexible during installation, and hear a clear sound of "Da" when pushing in the cards completely, it indicates that the cards are installed in the correct direction; if there is obvious friction resistance during installation, it indicates that the installation direction is wrong. Take out the cards in time to avoid any damage to the cards and the card holder.

If the Micro SD card and SIM card are too small to be pushed in the card slot completely by hand, you can put the card in the card slot and then push it in with the crowbar included in the package.

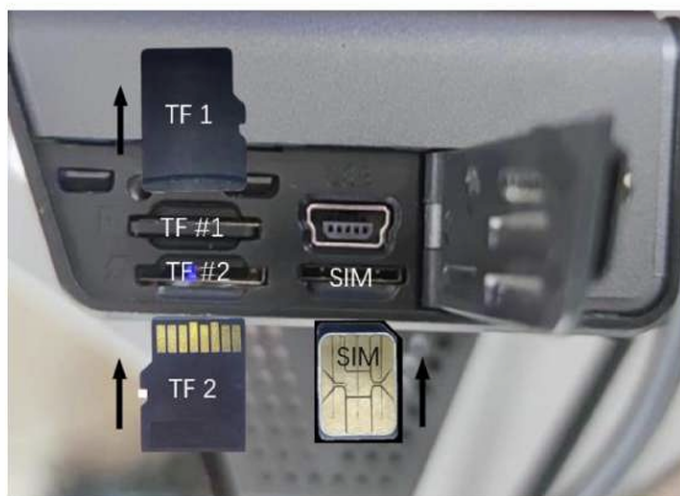



**\*Note:**

(1) Because the operating temperature range of the device is  $-40^{\circ}\text{C}$  to  $+70^{\circ}\text{C}$ , the Micro SD card and SIM card shall be able to function well in some harsh environments for a long time. Specifically, the metal contact on consumer-grade Micro SD cards and SIM cards is easy to oxidize under prolonged hot, humid, or salt-mist conditions. Frequent card pulling and pushing can lead to wear on the contact, and poor contact will also be caused by the deformed and bent ordinary cards due to the long-term pressure of the card holder. Therefore, if you use a SIM card, it is recommended to use an industrial plastic or ceramic M2M card for industrial devices (MP2/MP3/MS1 grade, operating temperature range  $-40^{\circ}\text{C}$  to  $105^{\circ}\text{C}$ ). If you use a Micro SD card, it is required to use an industrial-grade Micro SD card, which can be used in a wide operating temperature range ( $-40^{\circ}\text{C}$  to  $85^{\circ}\text{C}$ ) and has strong stability. Failure to use the appropriate card as required may damage the accessories or even the device.

(2) Do not touch the surface of the metal contact of the SIM card with hands when taking and installing the card, for fear of contaminating the SIM card by dust and sweat stain.

(3) Before installing the SIM card, please check the surface of the metal contact of the SIM card for any dirt (such as dust, fingerprints and water stains). If any, clean the surface with a piece of non-woven fabric or rubber.

(4) In TF card slot 1, the Micro SD card shall be pushed in with the metal strip side facing down; in TF card slot 2, the Micro SD card shall be pushed in with the metal strip side facing up.

After installation of the SIM card and Micro SD card, fasten the card slot panel and tighten the screws. After installation of the SIM card and Micro SD card, remove the lens protection stickers on the front and rear lenses of the Dashcam, and tear off the protective film on the LED light on the front panel, as shown in the figure below.



### Selection of Dashcam Installation Area

- (1) The Dashcam must be installed in the middle of the front windshield. It is generally installed in the rearview mirror area above the centerline of the front windshield.
- (2) When conditions permit, the height of the DSC lens shall not exceed the height of the driver's eyes, and the installation position shall be as low as possible provided that the driver's view is not obstructed. The linear distance from the position of the DSC lens to the driver's face shall not be more than 46 in(116 cm).
- (3) The lens for road condition monitoring of the Dashcam must be within the working range of the left and right wipers (to ensure that the screen of the lens for road condition monitoring is clean and free from stains).
- (4) The preferred vertical distance from the lens for road condition monitoring of the Dashcam to the ground is in the range of 52 in -95 in(130 cm-240 cm).
- (5) Avoid installing other electronic devices around the Dashcam as far as possible, including ETC, intelligent rearview mirrors, and electronic tags; otherwise, they may affect the positioning signal of the device. The installation position shall be determined in such a way that the Dashcam will not hinder the driver from viewing the front blind spot reflector, and there is no obstruction (such as interior rearview mirror or glass coating) within the field of view in front of and around the lens for cockpit monitoring and lens for road condition monitoring.

The installation area is generally selected as shown in the figure below:

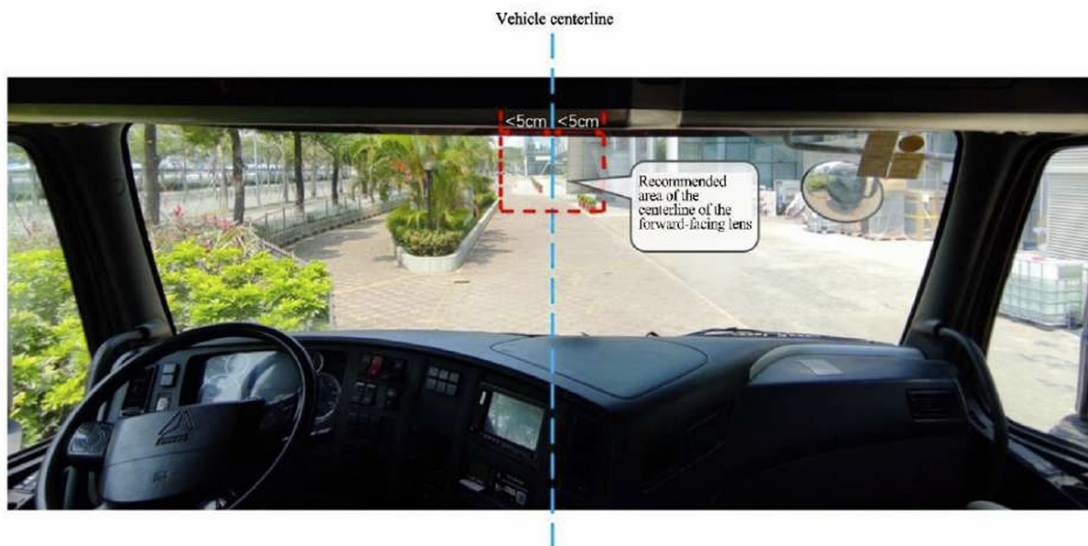



### **Installation of Dashcam Bracket**

Park the vehicle on the horizontal ground, clean the interior and exterior of the glass in the target installation area with alcohol cotton to ensure that no dirt on the glass in this area will affect the angle of view of the lens for road condition monitoring, and ensure the glass is dry.

Tear off the 3M adhesive tape, install the bracket horizontally on the target installation area of the front windshield (the upper edge of the bracket should be parallel to the upper edge of the windshield) according to the direction indicated by the arrow on the bracket, and press the bracket for 3-5min to ensure that no air bubbles remain between the bracket and the glass.

Note: When installing the bracket, install the bracket according to the direction indicated on the bracket, so that the toothed side faces to the right.



### Installation of Dashcam

Connect the Dashcam to the bracket with the front side facing inward (with the teeth on the right side of the bracket engaged with those on the right inner side of the Dashcam), and tighten the bracket stud clockwise with a PH2 cross screwdriver (before tightening, first adjust the Dashcam to be vertical).



### **Angle Adjustment and Fixation of Dashcam**

Adjust the Dashcam back and forth so that it is vertical.

Fasten the bracket stud to ensure that the angle of the Dashcam will not be changed easily, and fix the Dashcam.

When fixing, ensure that the cockpit camera screen meets the following conditions:

- 1) The center of the cockpit shall be in the middle of the screen.
- 2) The cockpit screen shall be horizontal.
- 3) The vehicle steering wheel shall be shown at the lower left/right corner of the screen.

The cockpit rendering after the lens for cockpit monitoring is properly adjusted is as follows:



Use a screwdriver to fasten the bracket studs clockwise so that the Dashcam will not shake easily.

\*Note:

Make sure that the connection between the bracket and the Dashcam is fastened (the device is rigidly connected with the vehicle), so that the Dashcam will not shake easily. Otherwise, the GPS positioning will be inaccurate. Only after the Dashcam is firmly connected with the vehicle can the device be powered on. If the device is fixed and installed after power-on, it shall be powered on again before being tested or used. The GPS module built in is an inertial navigation module, and the above requirements can ensure the normal operation of inertial navigation products.

### **Power Supply Connection**

If the mode of quick power supply connection through the OBD port is adopted, locate the OBD port of the vehicle and directly connect with the port.



If the mode of power supply connection through the loose wire is adopted, according to the definition of power loose wire, connect POWER/ACC/GND with the power cable of the vehicle, respectively.

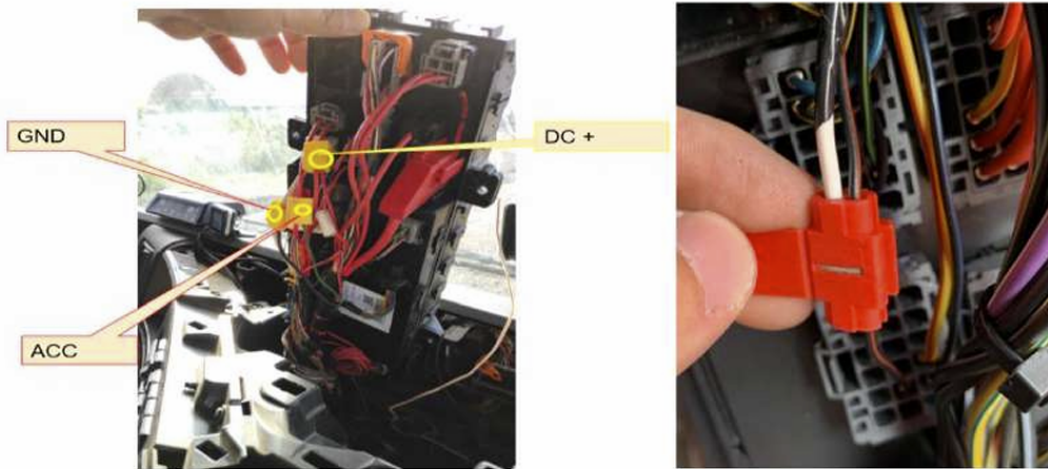
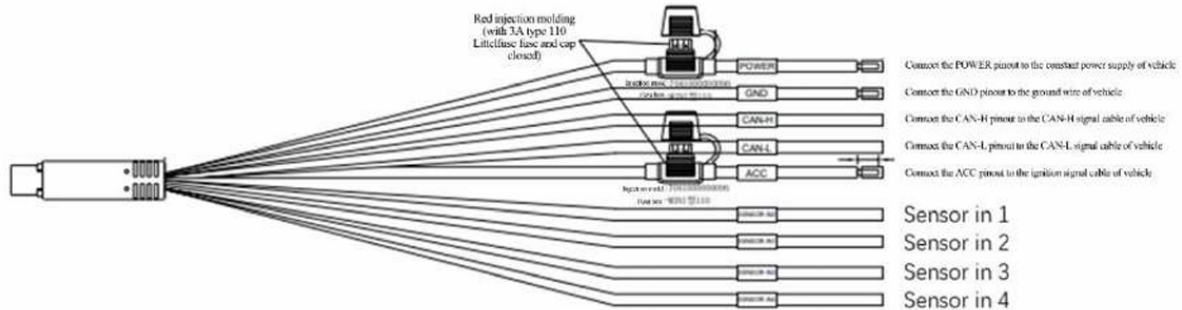

\*Note:

The power line shall be connected using "special stripping-free connection terminal" where possible (no stripping is required, so as to avoid the risk of electric leakage), and the connection shall be wrapped with insulated rubber tape to avoid electric leakage/short circuit. If there is no special stripping-free connection terminal, stripped wires can also be used for connection. In this case, the connection process must conform to the standard specifications. After the connection is completed, the connection shall be wrapped with insulated rubber tape to avoid electric leakage/short circuit.

### Connection of Signal Cables (CAN/Left/Right Steering Signal/Reversing)

**\*Note: this is for Lane Departure Warning Features**

Review the vehicle manual to locate the OBD port of the vehicle. Generally, the position of the OBD port of the vehicle is as shown in the figure below. Locate CAN-H and CAN-L cables of the vehicle behind the OBD port. Take the standard 16PIN inverted trapezoidal OBD port as an example, CAN-H and CAN-L cables generally correspond to pins 6 and 14, respectively. (The cable sequence varies with the shape of the OBD port. The example here is only for illustration.)

## General Positions of OBD Port of Different Vehicle Models

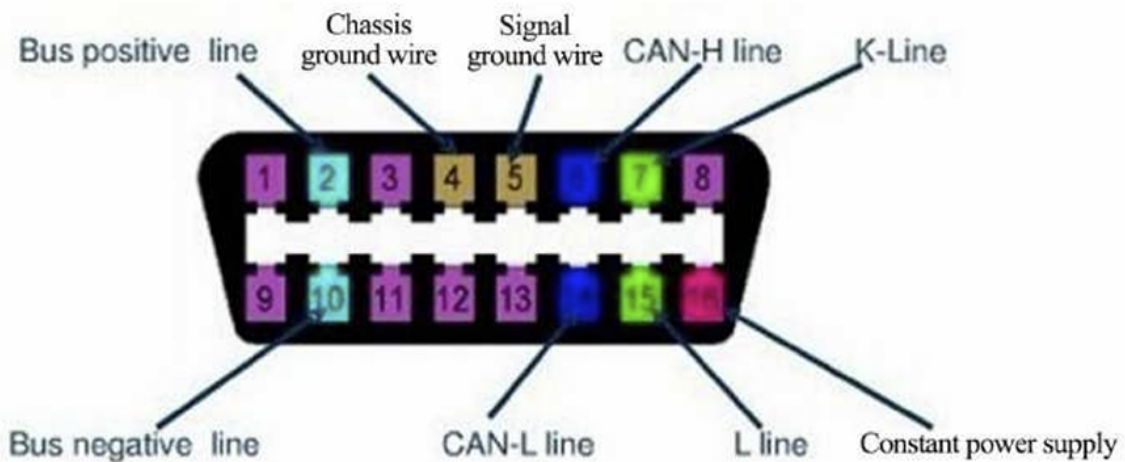
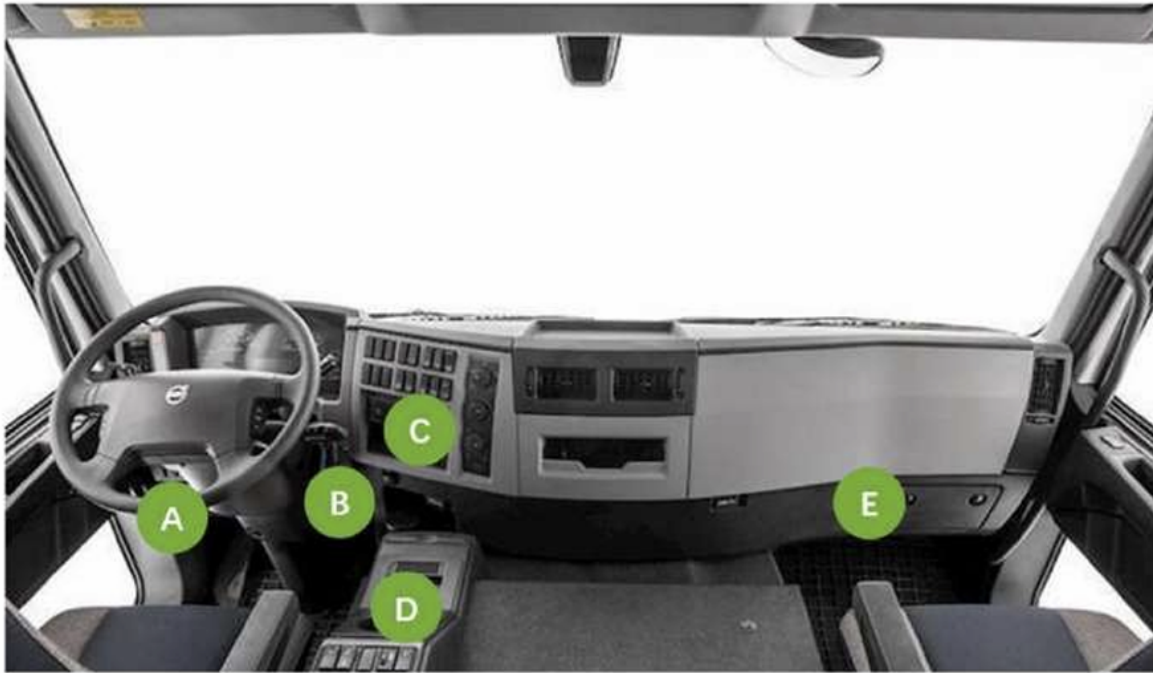

Left steering/right steering/reversing signal After locating the fuse board below the steering wheel or the front passenger dashboard, measure the cable corresponding to left steering/right steering/reversing signal according to the tips on the cover back of the fuse board or using a multimeter. There are four IO signal cables in the standard loose wire, so left steering, right steering, and reversing signals can be connected.



\*Note:

If the measured signal is a pulse signal, the source of left steering/right steering shall be set as pulse on the setting screen of the Dashcam; if the measured signal is a continuous high or low level signal, the source of left steering/right steering shall be set as level on the setting screen of the Dashcam.

### Cabling

Upon the completion of connection of main cables according to the schematic diagram of system connection, as well as power supply connection and connection of signal cables, arrange these cables using a crowbar according to the diagram below and conceal them in the interior trim panel or the panel of the dashboard (i.e. concealed cabling). If a DMS camera is required, the cable length of the DMS camera can be reserved for overall cabling.

(1) If the mode of power supply connection through the OBD port or loose wire is adopted, the cabling mode is as follows:



It is necessary to fix the power supply box at a certain position on the vehicle. Attention should be paid to the following items when the fixing position is selected:

- ① It should be close to the vehicle OBD port or loose wire power outlet.
- ② The mounting position should be flat.
- ③ It does not interfere with other components of the vehicle.
- ④ It keeps away from loudspeakers, engines, and other positions with excessive shake or vibration.
- ⑤ It should be as secluded as possible.

Due to the different positions of the OBD port of different vehicles, the corresponding cabling methods and the fixing position of the power supply box are also different. Here are two recommended installation positions for the power supply box. You can also fix it in other positions according to the actual vehicle.

Fixing position 1 of the power supply box:

Remove the side baffle of the driving seat, tear off the 3M tape on the power supply box, and fix it to the left or right baffle, as shown below:



Fixing position 2 of the power supply box:

Fix the power supply box on the right baffle of the driving seat with exposed cabling. Since the left baffle may interfere with the door, it is not recommended to install it on the left baffle with exposed cabling. After selecting the fixing position, tear off the 3M tape on the power supply box and fix it on the right baffle of the driving seat, as shown below:

